

## 68970E.59.066

Miscelatore monocomando ad incasso con deviatore automatico a 2 uscite. Parte esterna. Ingressi ed uscite da 1/2". - finitura PVD Acciaio Spazzolato



### CARATTERISTICHE

Materiale	<b>Ottone</b>
Installazione	<b>Incasso a parete</b>
Tipologia di comando	<b>Monocomando</b>
Tipologia deviatore	<b>Con deviatore Automatico</b>
Uscite	<b>2 Uscite</b>
Miscelazione dell' acqua	<b>Meccanica</b>
Necessari per l'installazione	<b><u>10843.00.000</u></b>

### DISEGNO TECNICO

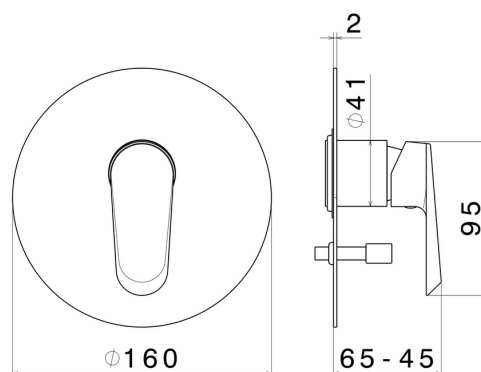



**68970E.59.066**

Miscelatore monocomando ad incasso con deviatore automatico a 2 uscite. Parte esterna. Ingressi ed uscite da 1/2". - finitura PVD Acciaio Spazzolato

**FINITURE DISPONIBILI**

---



**59.066**

PVD Acciaio Spazzolato



**01.093**

finitura Nero opaco



**21.018**

finitura Cromo



**59.097**

finitura PVD Brushed Gold